

AXIS BENCH - PLINTH MOUNT

FFSC001081 - 1800mm Bench - Plinth Mount

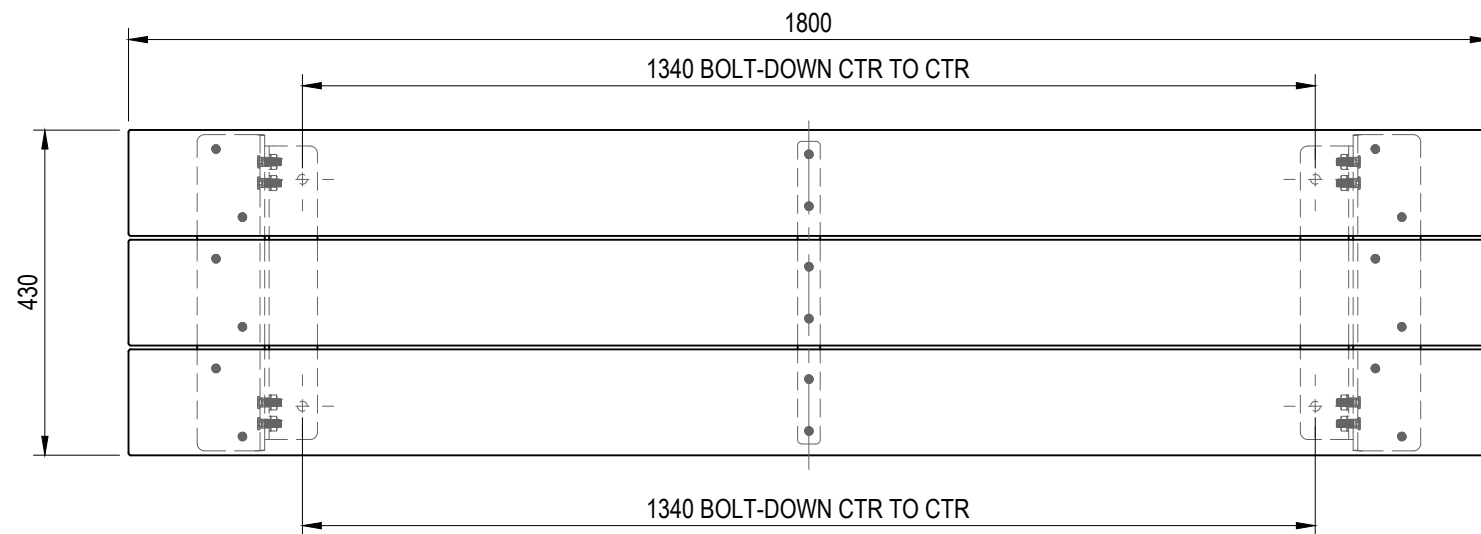

TOP VIEW

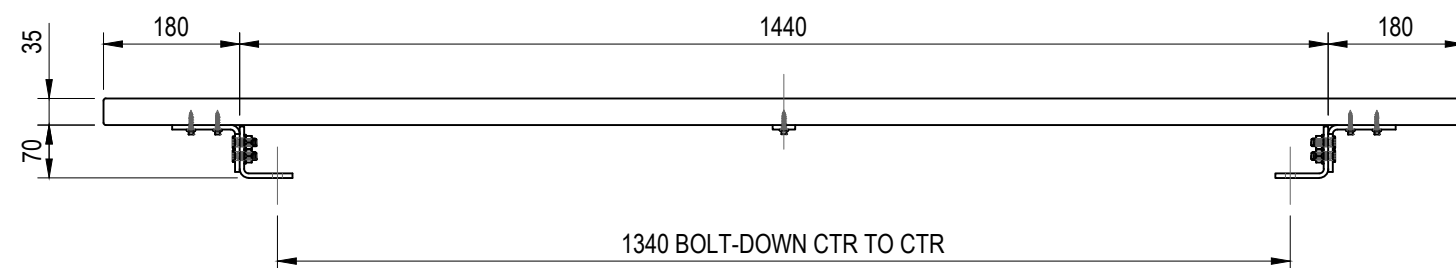

FRONT VIEW

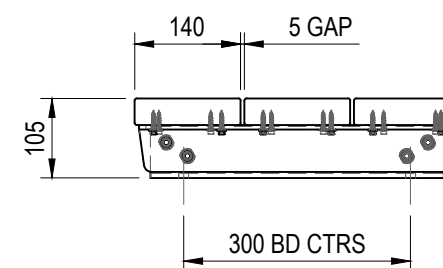

END VIEW

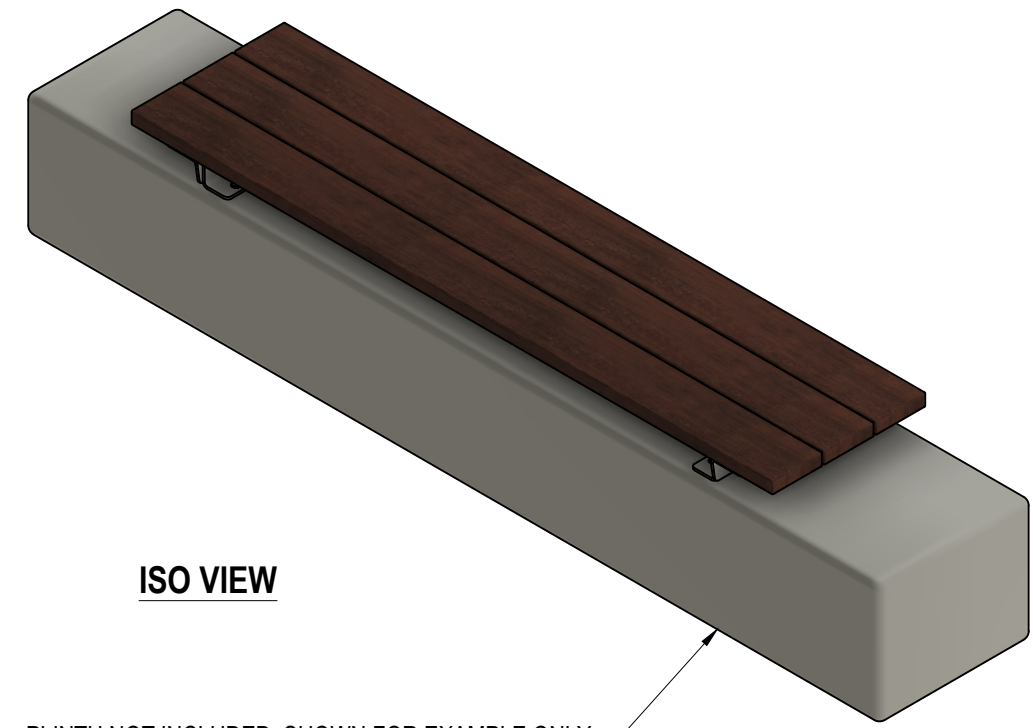

ISO VIEW

PLINTH NOT INCLUDED, SHOWN FOR EXAMPLE ONLY

SPECIFICATIONS:

- FRAME:** STAINLESS STEEL 304 GRADE & POWDERCOAT FINISH
- FIXINGS:** STAINLESS STEEL UNLESS NOTED OTHERWISE
- SLATS:** KILN DRIED HARDWOOD DRESSED ALL SIDES WITH PENCIL ROUNDED EDGES

Revision History			
Rev	Description	Date	Approved

FURPHY FOUNDRY PTY LTD.

THIS DOCUMENT IS AND SHALL REMAIN THE PROPERTY OF FURPHY FOUNDRY. UNAUTHORISED USE OF THIS DOCUMENT IN ANY FORM IS PROHIBITED.

UNLESS OTHERWISE SPECIFIED, DIMENSIONS ARE IN mm
DO NOT SCALE
 BREAK ALL SHARP EDGES AND REMOVE BURRS

TOLERANCES
 X: ±0.25
 Y: ±0.1
 XX: ±0.05
 ANGLES: ±0.1°

FURPHY
 FOUNDRY EST. 1864

Furphy Foundry Pty Ltd
 A.B.N. 24 007 195 913
 21 Drummond Rd,
 Shepparton VIC 3630

PH: (03) 5831 2777
 FAX: (03) 5831 2681
 www.furphyfoundry.com.au
 sales@furphyfoundry.com.au

CLIENT NAME FURPHY FOUNDRY	PROJECT No. FFSC001081	PAGE A3
PROJECT Axis Furniture Range FFSC001081 - 1800mm Bench - Plinth Mount	DATE: 30/07/2024	DRAWN Joel Rose
DRAWING TITLE 1800mm Bench - Plinth Mount	DRAWING No. FFSC001081	SCALE 1:10
PART No. FFSC001081	SHEET No. 1/2	REV.

AXIS BENCH - PLINTH MOUNT

FFSC001081 - 1800mm Bench - Plinth Mount - Arm Rest

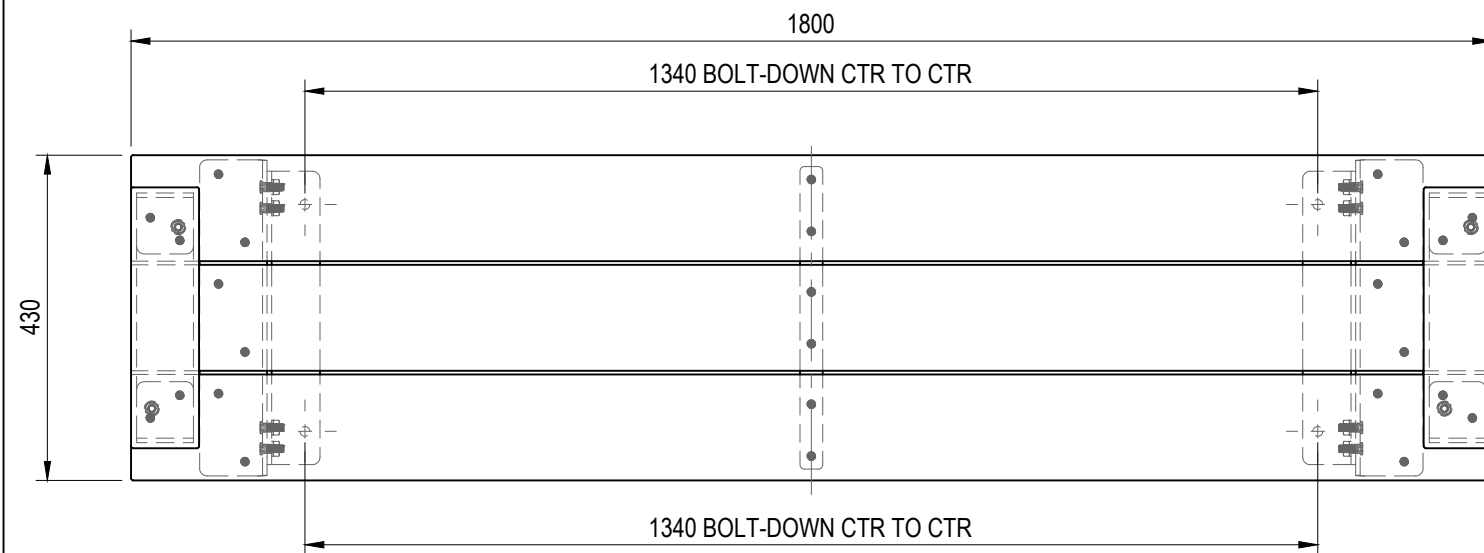

TOP VIEW

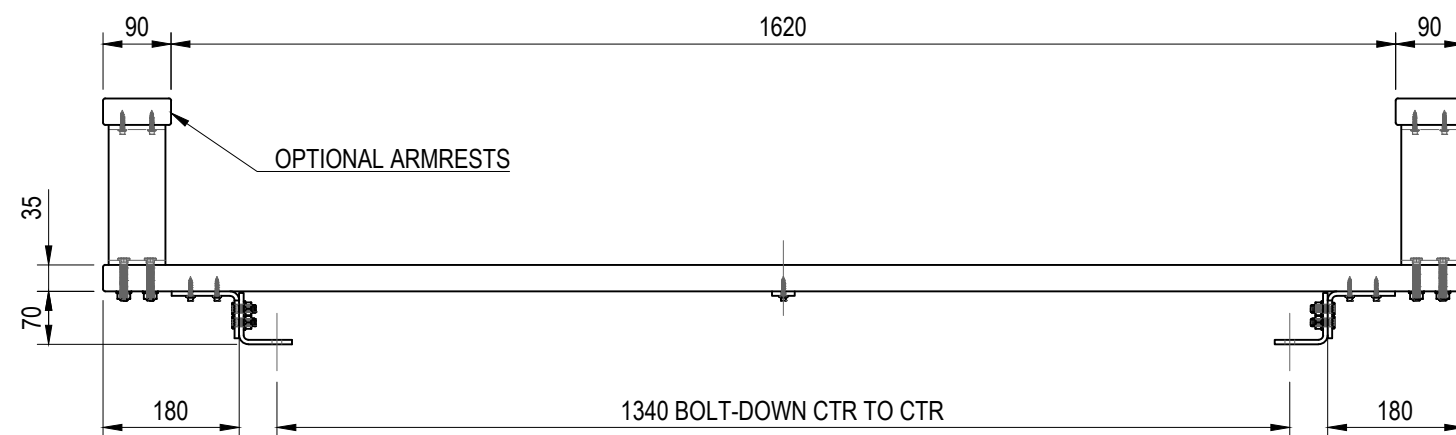

FRONT VIEW

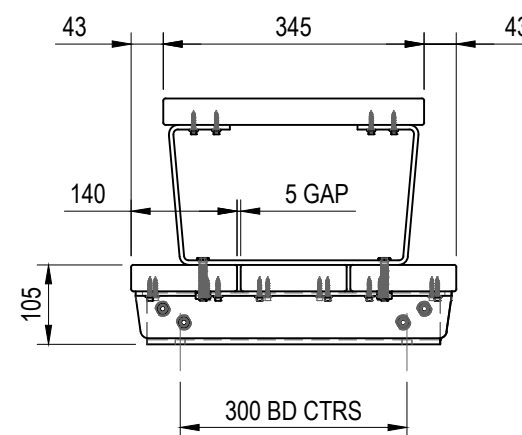

END VIEW

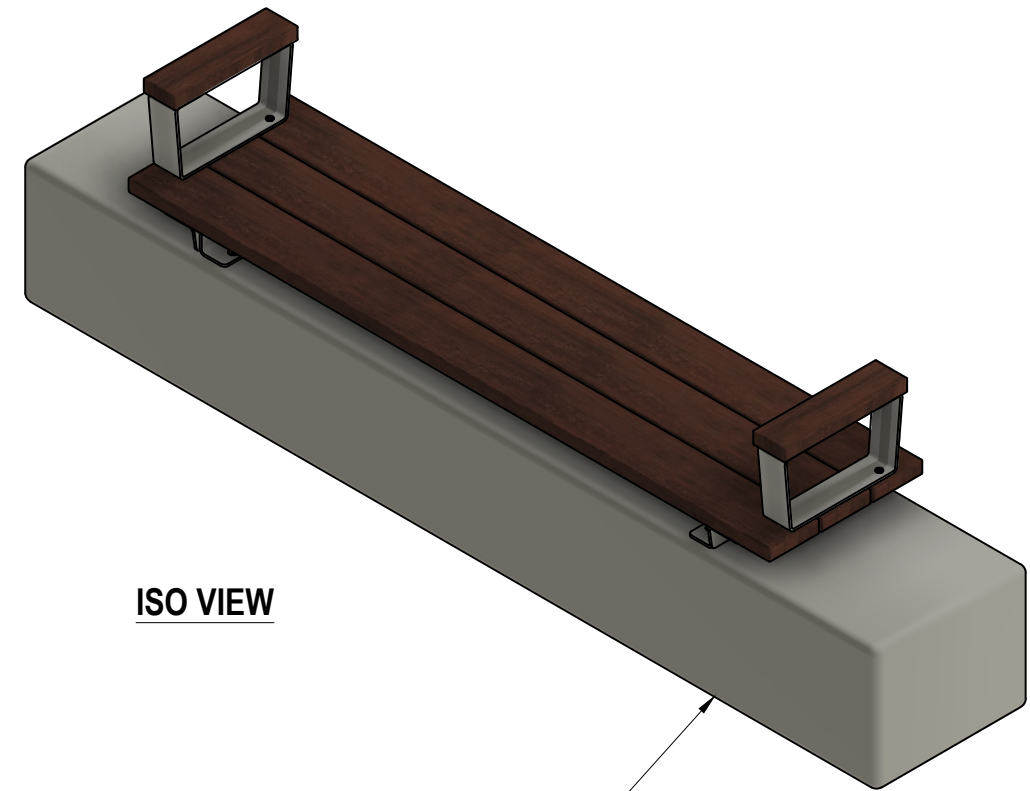

ISO VIEW

PLINTH NOT INCLUDED, SHOWN FOR EXAMPLE ONLY

SPECIFICATIONS:

- FRAME:** STAINLESS STEEL 304 GRADE & POWDERCOAT FINISH
- FIXINGS:** STAINLESS STEEL UNLESS NOTED OTHERWISE
- SLATS:** KILN DRIED HARDWOOD DRESSED ALL SIDES WITH PENCIL ROUNDED EDGES

Revision History			
Rev	Description	Date	Approved

FURPHY FOUNDRY PTY LTD.

THIS DOCUMENT IS AND SHALL REMAIN THE PROPERTY OF FURPHY FOUNDRY. UNAUTHORISED USE OF THIS DOCUMENT IN ANY FORM IS PROHIBITED.

UNLESS OTHERWISE SPECIFIED, DIMENSIONS ARE IN mm
DO NOT SCALE
BREAK ALL SHARP EDGES AND REMOVE BURRS

TOLERANCES
X: ±0.25
Y: ±0.1
XX: ±0.05
ANGLES: ±0.1°

FURPHY
FOUNDRY EST. 1864

Furphy Foundry Pty Ltd
A.B.N. 24 007 195 913
21 Drummond Rd,
Shepparton VIC 3630

PH: (03) 5831 2777
FAX: (03) 5831 2681
www.furphyfoundry.com.au
sales@furphyfoundry.com.au

CLIENT NAME FURPHY FOUNDRY	PROJECT No. FFSC001081	PAGE A3
PROJECT Axis Furniture Range FFSC001081 - 1800mm Bench - Plinth Mount - Arm Rest	DATE: 30/07/2024	DRAWN Joel Rose
DRAWING TITLE 1800mm Bench - Plinth Mount	PART No. FFSC001081	SCALE 1:10
	SHEET No. 2/2	REV.