

ALL DIMENSIONS IN MILLIMETRES - DO NOT SCALE

# IMPACT SECURITY RANGE

FFSB014008 - Planter Box - 1800mm Rectangle

Approx. Weight: 846.05 kg

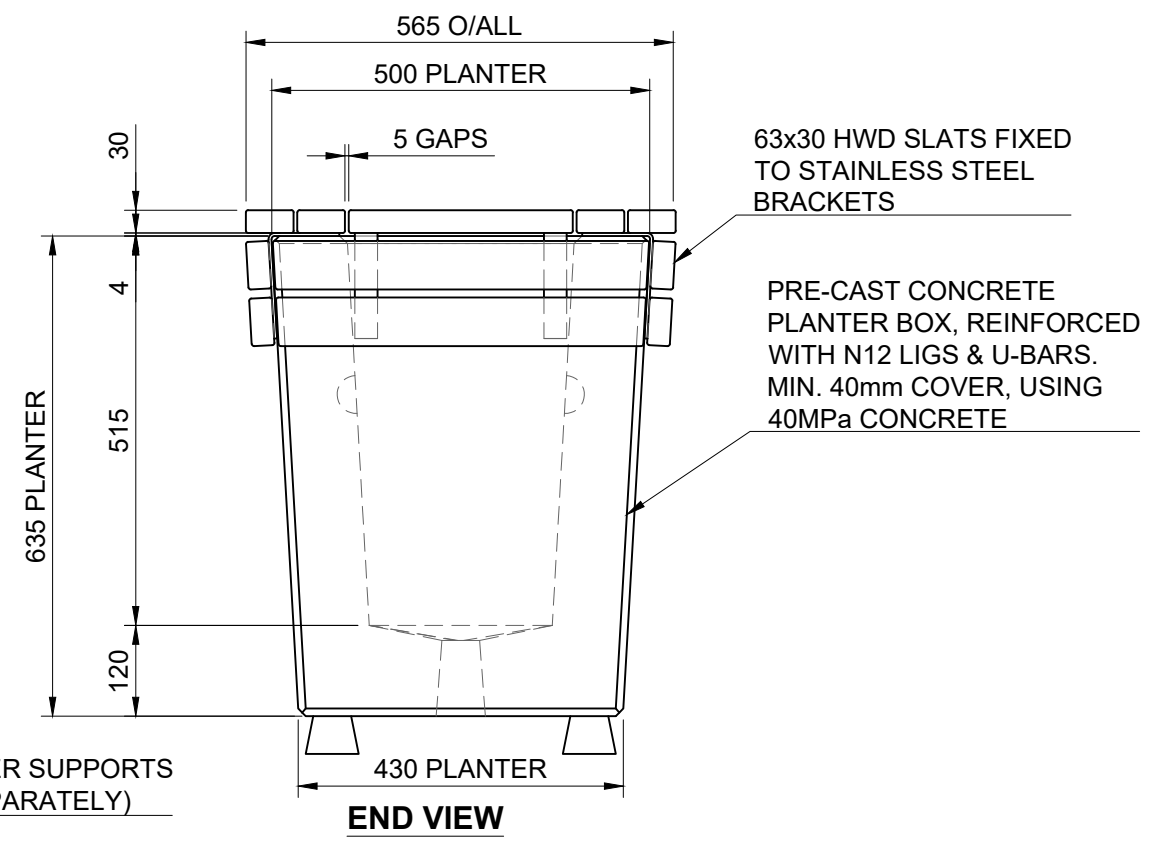
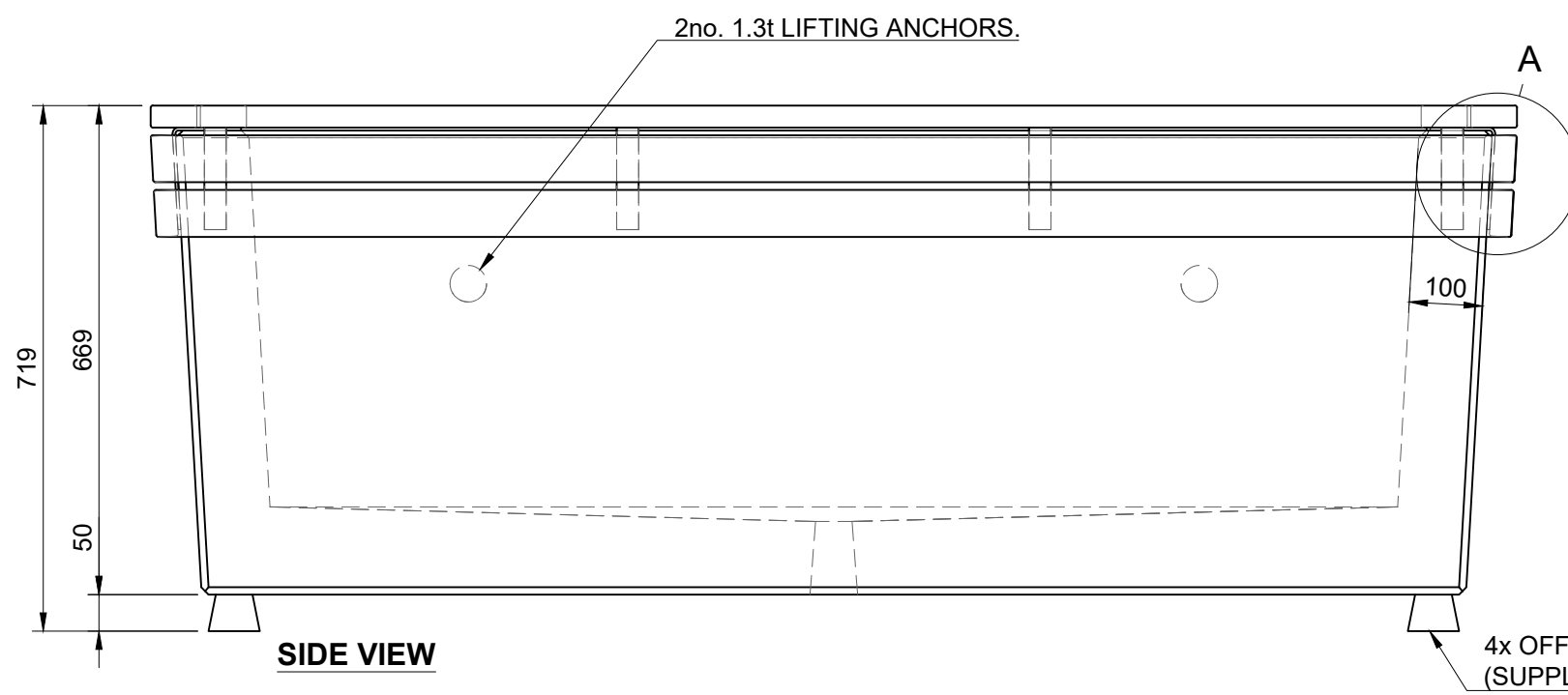
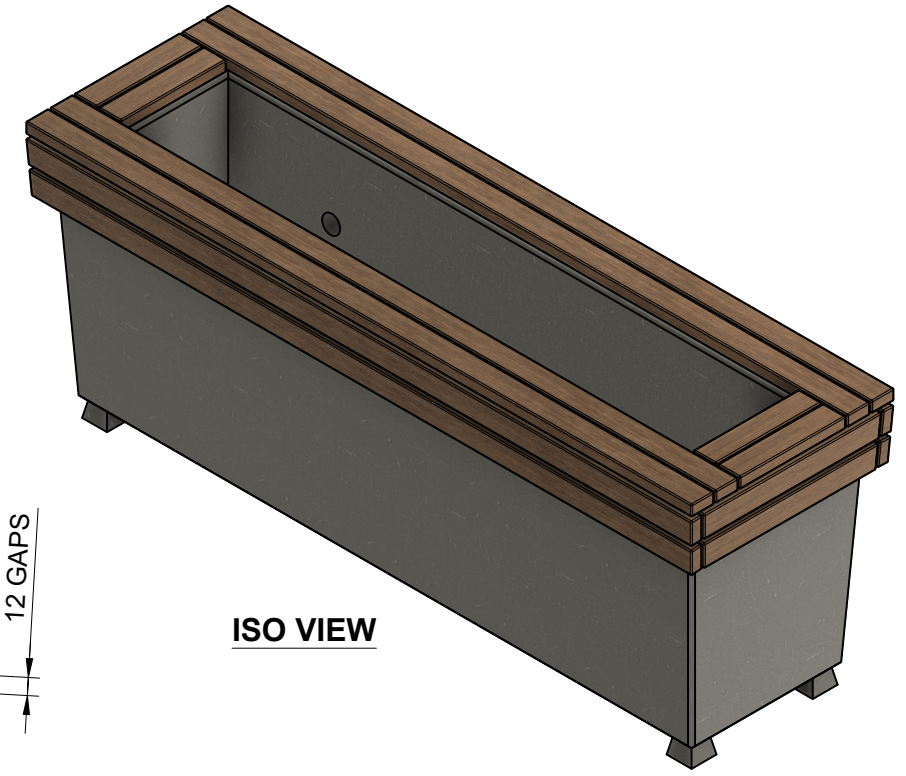
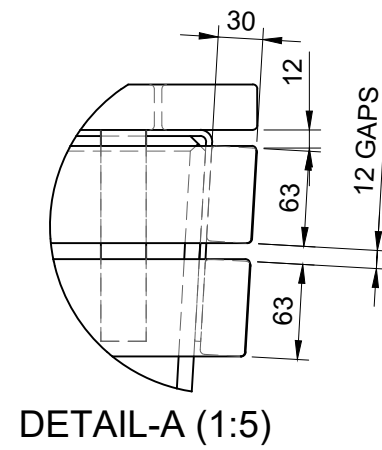
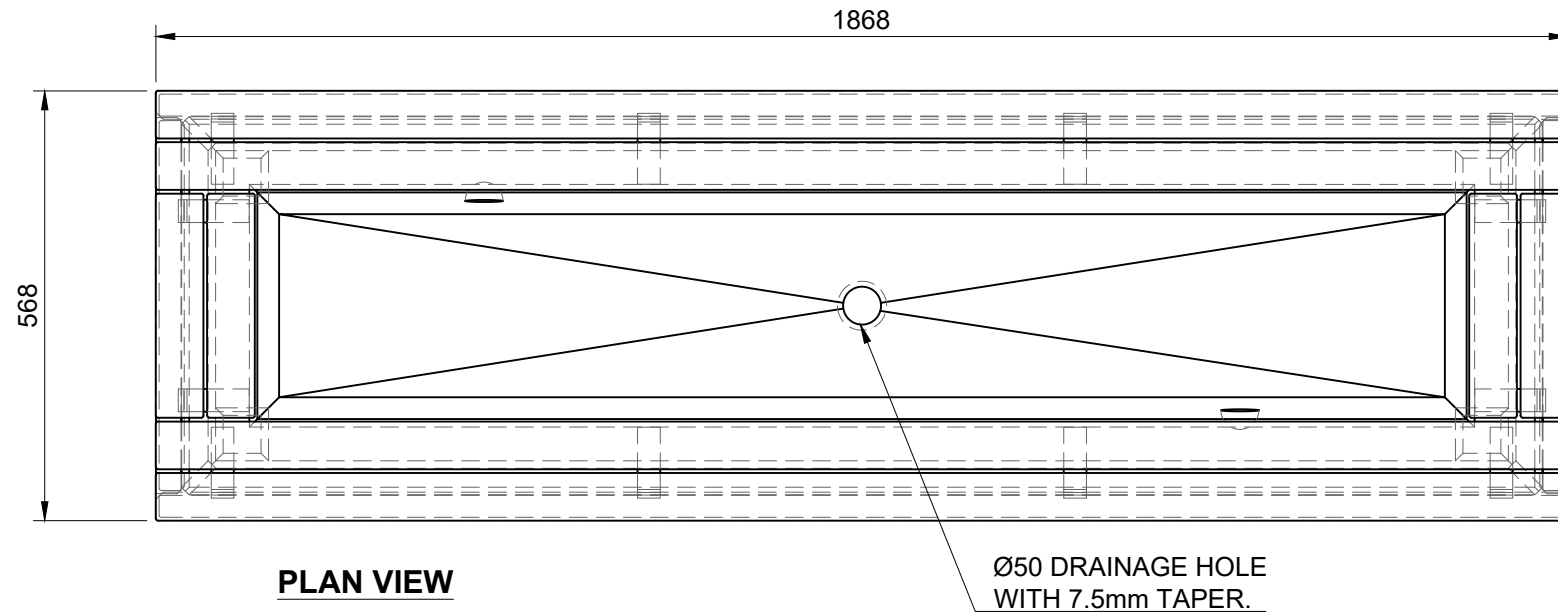

<b>Revision History</b>				<p>© LANDMARK PRODUCTS PTY LTD</p> <p>THIS DOCUMENT IS AND SHALL REMAIN THE PROPERTY OF LANDMARK PRODUCTS PTY LTD. UNAUTHORISED USE OF THIS DOCUMENT IN ANY FORM IS PROHIBITED.</p>	<p><b>Landmark</b> open space structures &amp; solutions</p>	CLIENT NAME	PROJECT No.	PAGE
Rev	Description	Date	Approved			Landmark Products Pty Ltd	FFSB014008	A3
				<p>CHECKED BY: _____ DATE: _____</p>	<p>Landmark Products Pty Ltd PH: (03) 5831 2777 A.B.N. 99 112 000 843 FAX: (03) 5831 2681 6 / 26 Flinders Parade, Northlakes, QLD 4509 www.landmarkproducts.com.au landmark@landmarkpro.com.au</p>	PROJECT	DATE:	DRAWN
						FFSB014008 - Planter Box - 1800 Rectangle	31/10/2024	Joel Rose
						DRAWING No.	SCALE	
						DWG SPEC	1:10	
						DRAWING TITLE	PART No.	SHEET No.
						Planter Box - 1800mm Rectangle	FFSB014008	1/1
								REV.