

CIVIC TABLE WCA2

FFSB003019 - 1800mm TABLE WHEELCHAIR ACCESS x2 - BOLT DOWN

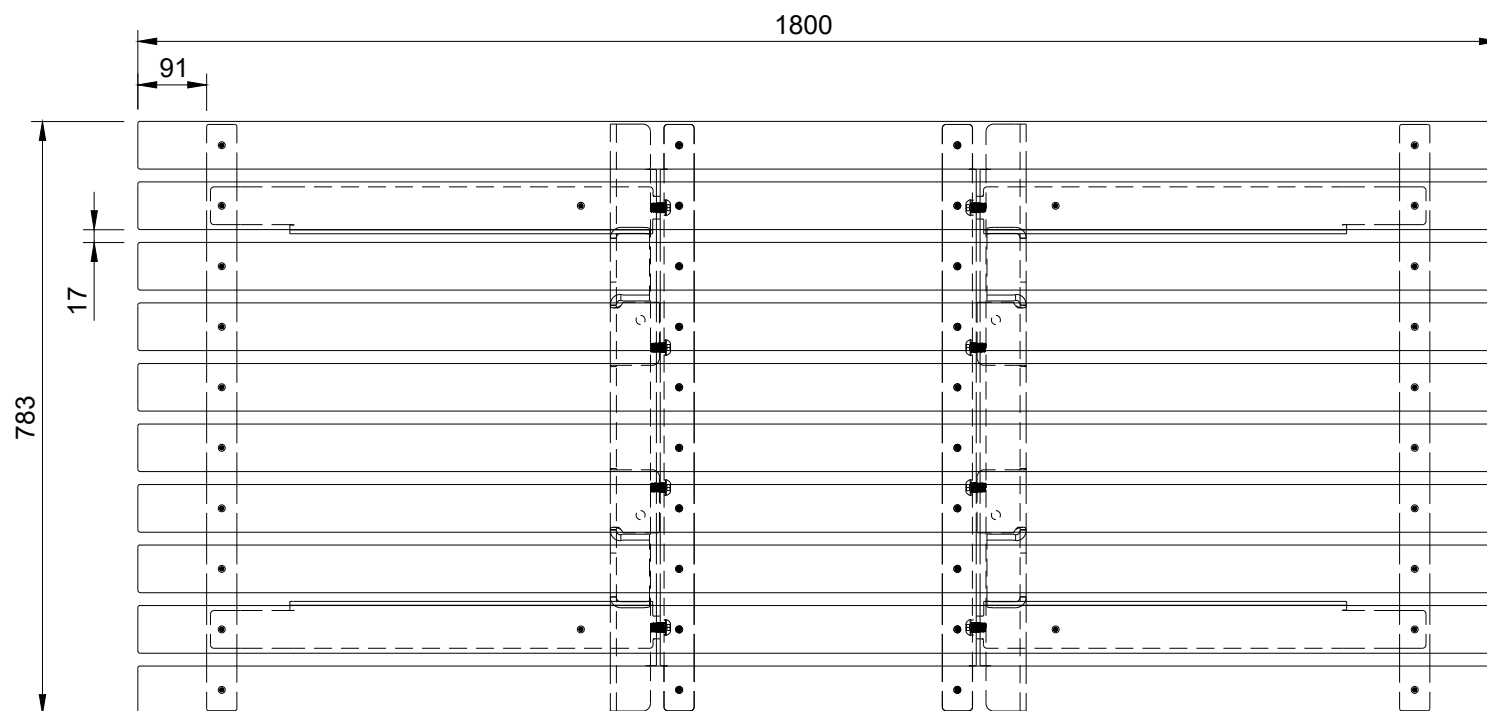

TOP VIEW

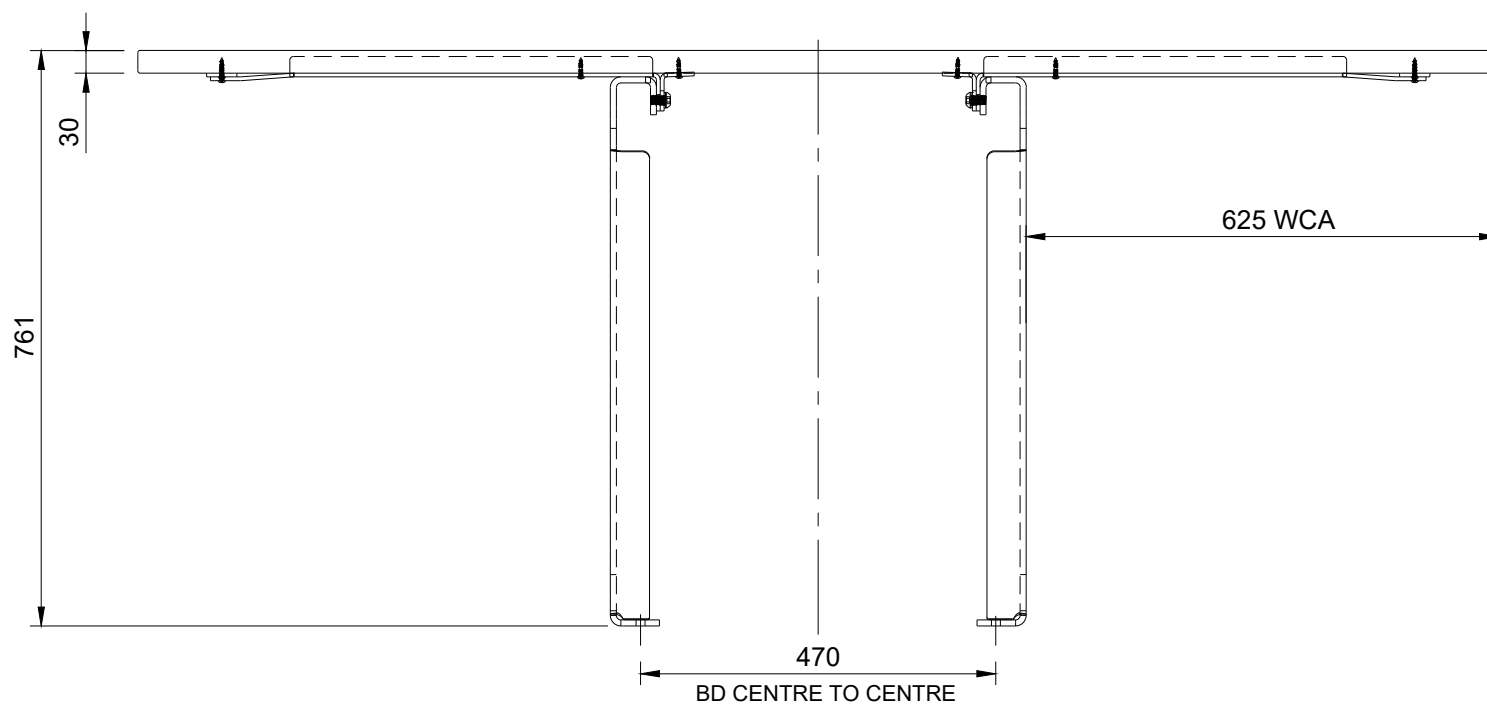

FRONT VIEW

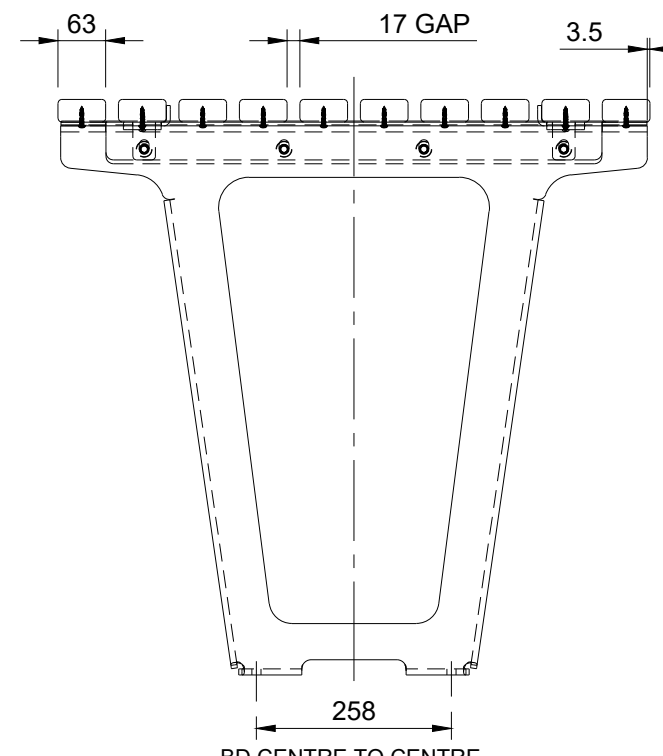

SIDE VIEW

SPECIFICATIONS SLATS

CODE	MATERIAL SLATS	FINISH SLATS	MATERIAL FIXINGS
FFSB003019	HARDWOOD TIMBER	STANDARD STAIN	STAINLESS STEEL
FFSB003019A	ALUMINIUM	CLEAR ANODISED	STAINLESS STEEL
FFSB003019APC	ALUMINIUM	POWDER COATED	STAINLESS STEEL
FFSB003019ATE	ALUMINIUM	TIMBER EFFECT	STAINLESS STEEL

PACAKING OPTIONS (2)

1:20

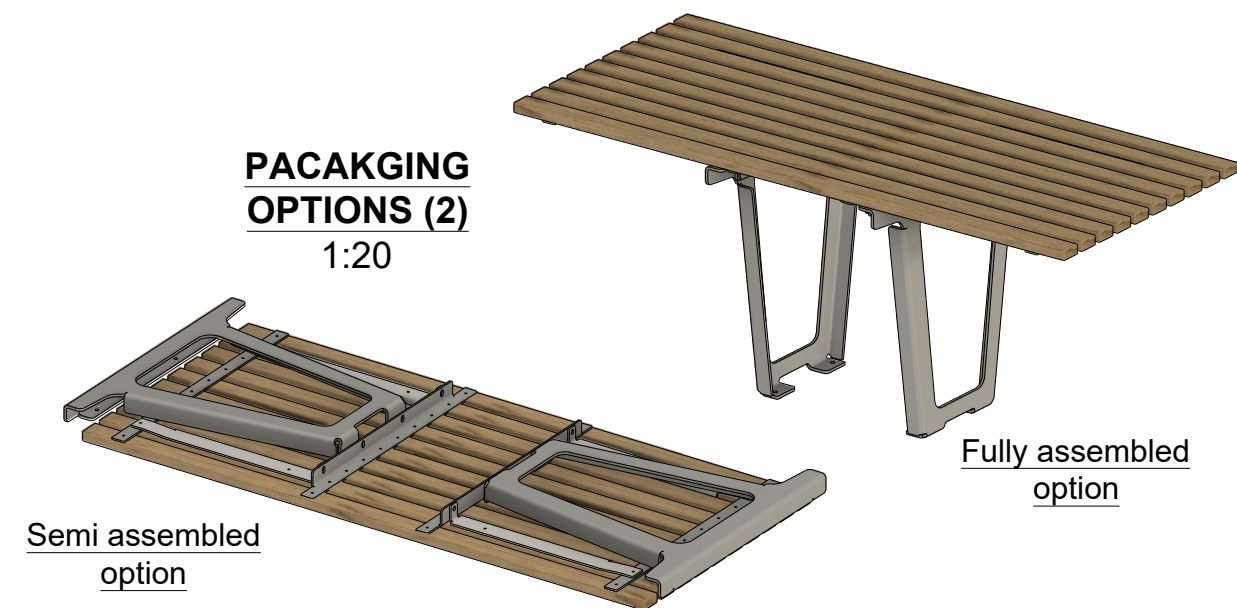

SPECIFICATIONS:

MAIN CONSTRUCTION

MATERIALS:

- Legs - Mild Steel
- Brackets - Stainless Steel 304

FINISH:

- STANDARD:
 - E-coated and Powder coated
- OPTIONAL:
 - Hot dipped galvanised and powder coated
 - Hot dipped galvanised only (no coating)

GROUND FIXING OPTIONS

- Bolt Down (BD): M10 x 75mm Bolt Screw Anchor GAL
- In Ground (IG): J Bolt Kit GAL

REV	DESCRIPTION	DATE	APPROVED

© FURPHY FOUNDRY PTY LTD
 THIS DOCUMENT IS AND SHALL REMAIN THE PROPERTY OF FURPHY FOUNDRY. UNAUTHORISED USE OF THIS DOCUMENT IN ANY FORM IS PROHIBITED.
 UNLESS OTHERWISE SPECIFIED, DIMENSIONS ARE IN mm
DO NOT SCALE
 BREAK ALL SHARP EDGES AND REMOVE BURRS

TOLERANCES
 X: ±0.25
 Y: ±0.1
 XX: ±0.05
 ANGLES: ±0.1°

FURPHY
 FOUNDRY EST. 1864
 Furphy Foundry Pty Ltd PH: (03) 5831 2777
 ABN 24 007 195 913 FAX: (03) 5831 2681
 21 Drummond Rd. www.furphyfoundry.com.au
 Shepparton VIC 3630 sales@furphyfoundry.com.au

CLIENT NAME FURPHY FOUNDRY		PROJECT No. FFSB003019	SIZE A3
PROJECT FFSB003019 Civic TABLE WCA2 BD		DATE 25/07/2024	DRAWN Ishwara Sanchez
PART NUMBER ----	MATERIAL ----	DRAWING No. DWG-000009	SCALE 1:10
		PAGE No. 1/2	