

# CIVIC BENCH

FFSB001017 - 1800mm BENCH - BOLT DOWN

SPECIFICATIONS SLATS			
CODE	MATERIAL SLATS	FINISH SLATS	MATERIAL FIXINGS
FFSB001017	HARDWOOD TIMBER	STANDARD STAIN	STAINLESS STEEL
FFSB001017A	ALUMINIUM	CLEAR ANODISED	STAINLESS STEEL
FFSB001017APC	ALUMINIUM	POWDER COATED	STAINLESS STEEL
FFSB001017ATE	ALUMINIUM	TIMBER EFFECT	STAINLESS STEEL

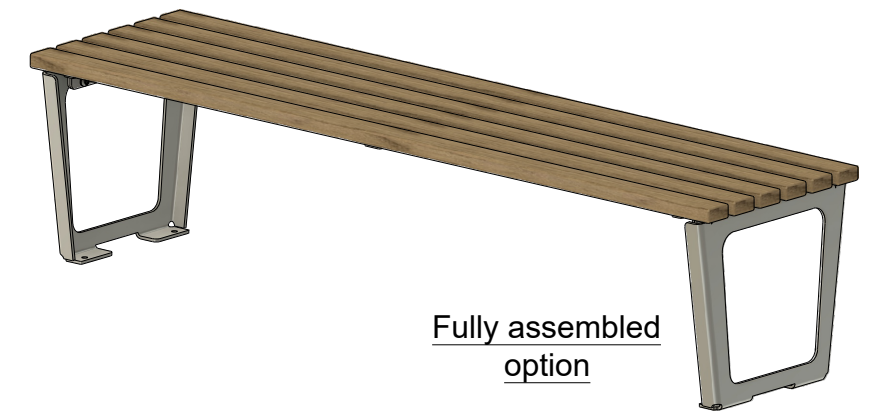

Fully assembled option

## PACKAGING OPTIONS (2)

1:15

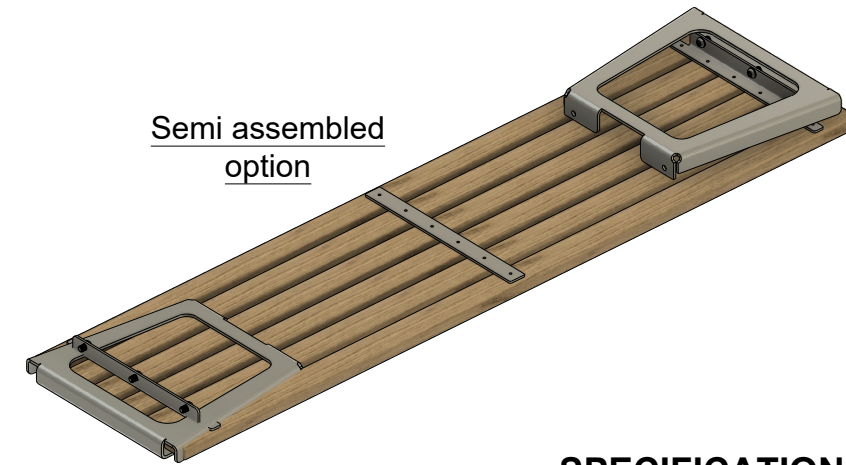

Semi assembled option

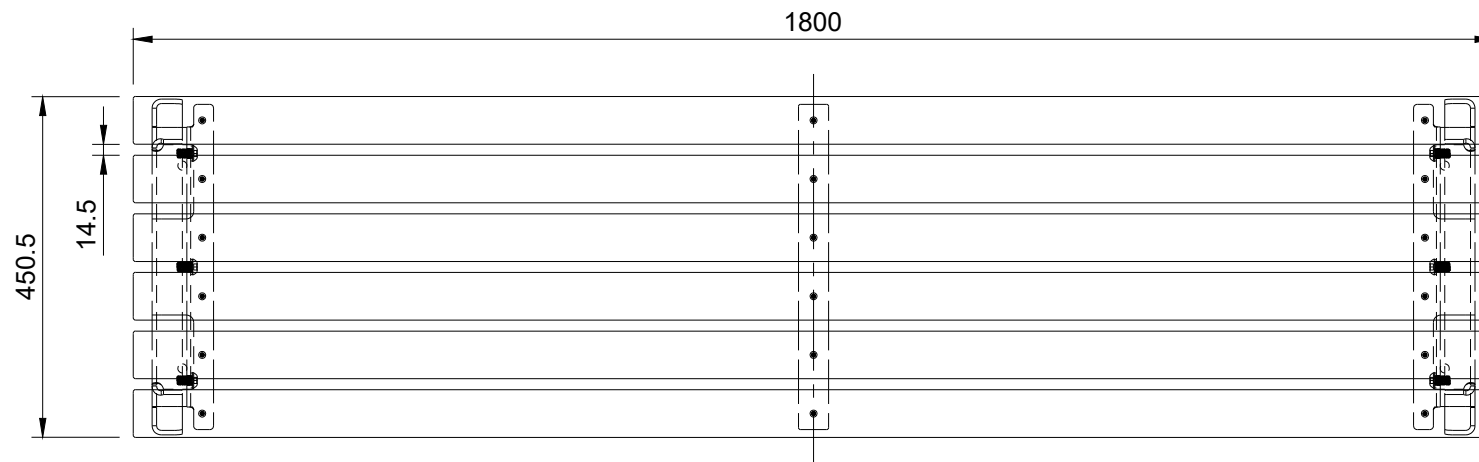

TOP VIEW

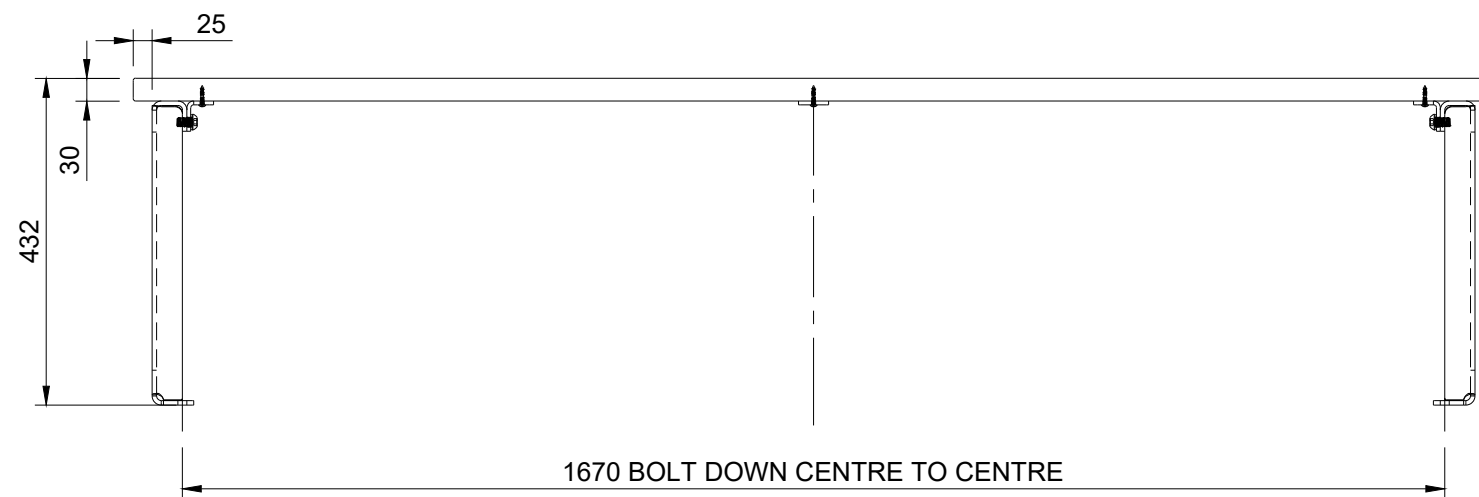

FRONT VIEW

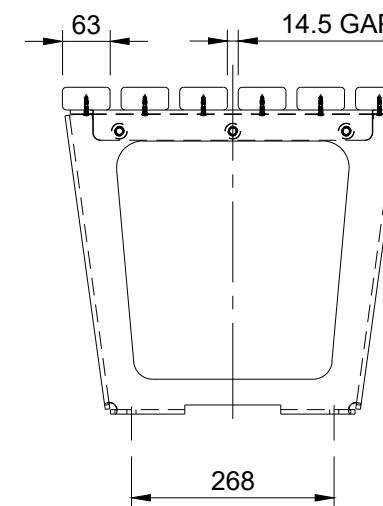

BD CENTRE TO CENTRE

SIDE VIEW

## SPECIFICATIONS:

### MAIN CONSTRUCTION

#### MATERIALS:

- Legs - Mild Steel
- Brackets - Stainless Steel 304

#### FINISH:

- STANDARD:
  - E-coated and Powder coated

#### OPTIONAL:

- Hot dipped galvanised and powder coated
- Hot dipped galvanised only (no coating)

#### GROUND FIXING OPTIONS

- Bolt Down (BD): M10 x 75mm Bolt Screw Anchor GAL
- In Ground (IG): J Bolt Kit GAL

				<p>© FURPHY FOUNDRY PTY LTD THIS DOCUMENT IS AND SHALL REMAIN THE PROPERTY OF FURPHY FOUNDRY. UNAUTHORISED USE OF THIS DOCUMENT IN ANY FORM IS PROHIBITED.</p>	<p>FURPHY FOUNDRY EST. 1864</p>	CLIENT NAME FURPHY FOUNDRY		PROJECT No. FFSB001017	SIZE A3
						PROJECT FFSB001017 Civic BENCH BD		DATE 22/07/2024	DRAWN Ishwara Sanchez
				UNLESS OTHERWISE SPECIFIED, DIMENSIONS ARE IN mm <b>DO NOT SCALE</b> BREAK ALL SHARP EDGES AND REMOVE BURRS	<p>TOLERANCES X: ±0.25 X: ±0.1 XX: ±0.05 ANGLES: ±0.1°</p>	PART NUMBER ----	MATERIAL ----	DRAWING No. DWG-000010	SCALE 1:15
REV	DESCRIPTION	DATE	APPROVED			PAGE No. 1/2			

UNLESS OTHERWISE SPECIFIED, DIMENSIONS ARE IN mm  
**DO NOT SCALE**  
BREAK ALL SHARP EDGES AND REMOVE BURRS

TOLERANCES  
X: ±0.25  
X: ±0.1  
XX: ±0.05  
ANGLES: ±0.1°

Furphy Foundry Pty Ltd  
ABN 24 007 195 913  
21 Drummond Rd.  
Shepparton VIC 3630  
PH: (03) 5831 2777  
FAX: (03) 5831 2681  
www.furphyfoundry.com.au  
sales@furphyfoundry.com.au

CLIENT NAME FURPHY FOUNDRY		PROJECT No. FFSB001017	SIZE A3
PROJECT FFSB001017 Civic BENCH BD		DATE 22/07/2024	DRAWN Ishwara Sanchez
PART NUMBER ----	MATERIAL ----	DRAWING No. DWG-000010	SCALE 1:15
		PAGE No. 1/2	