

**SPECIFICATION:**

**MATERIAL:**  
Main construction - Mild Steel  
Sheeting - Colourbond Corrugated BMT 0.42mm 762mm

**DIMENSIONS:**  
mm unless otherwise stated

**FINISH:**  
Steel - Galvanised - Colourbond (optional colours)

**GROUND ATTACHEMENT:**  
Bolt down

**STRUCTURAL ENGINEERING:**  
Job No. 090313 - GC Nixon & Associates  
Drawing No. S2 Rev A, Dated 17-06-09

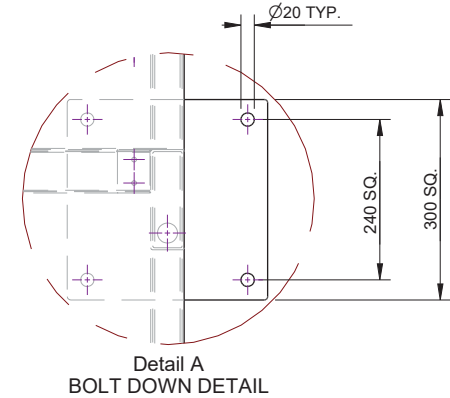
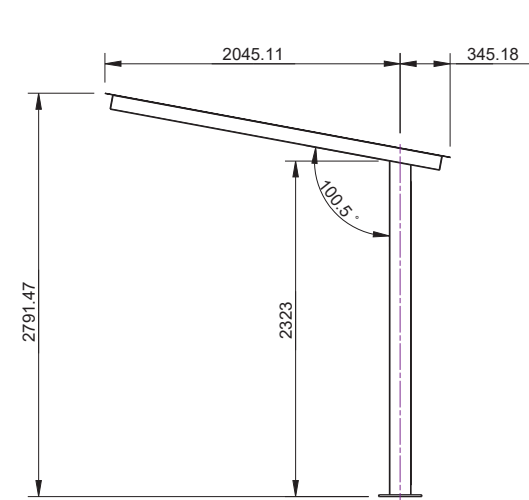
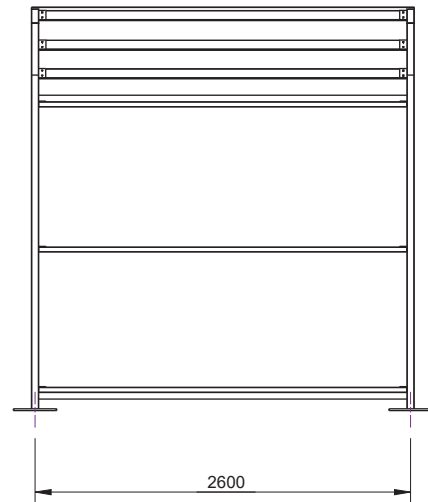
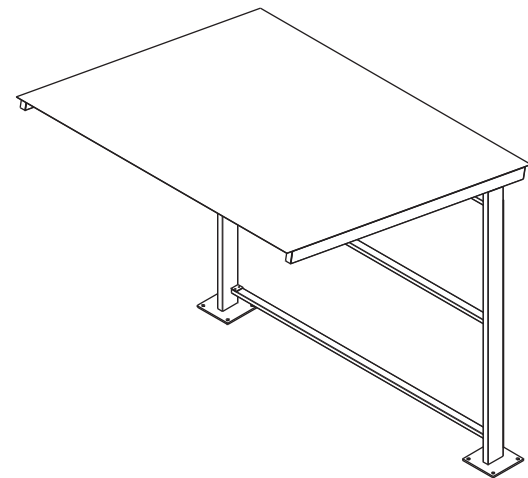
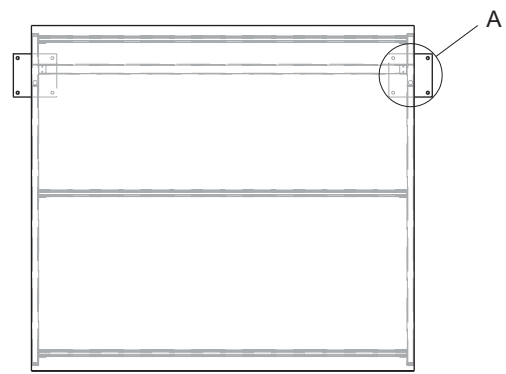

REVISION #	DESCRIPTION	BY	DATE	DRAWN	DRAWN DATE	CHECKED	CHECKED DATE	SCALE	A3
1	ORIGINAL DRAWING	SJ	14.2.11	R.CRIGTON	11.2.14			N/A	
2	FULL PRODUCT REVIEW	RBC	11.2.14						
3									
4									
5									

CANTILEVER SHELTER 2600mm CENTRES SPEC.

FFSB005001

REV. 2

SHEET 1 OF 3

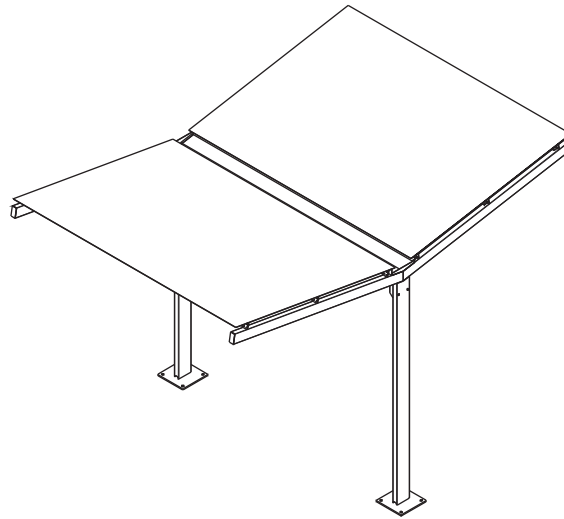
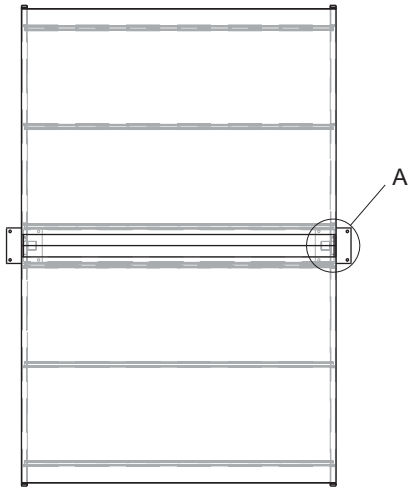

**SPECIFICATION:**

**MATERIAL:**  
Main construction - Mild Steel  
Sheeting - Colourbond Corrugated BMT 0.42mm 762mm

**DIMENSIONS:**  
mm unless otherwise stated

**FINISH:**  
Steel - Galvanised - Colourbond (optional colours)

**GROUND ATTACHEMENT:**  
Bolt down

**STRUCTURAL ENGINEERING:**  
Job No. 100511 - GC Nixon & Associates

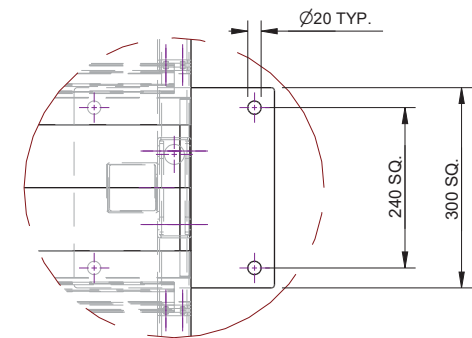
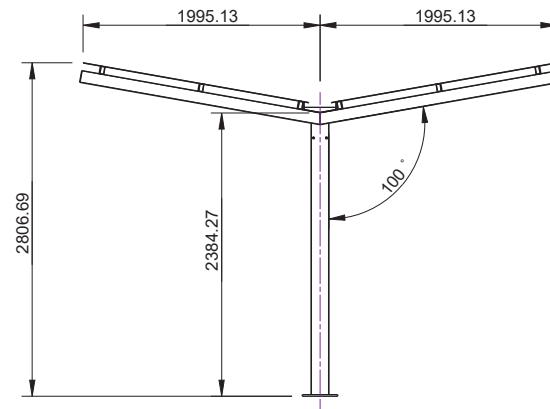
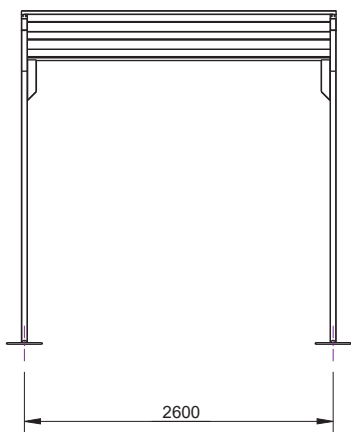

Detail A  
BOLT DOWN DETAIL

REVISION #	DESCRIPTION	BY	DATE	DRAWN	DRAWN DATE	CHECKED	CHECKED DATE	SCALE	A3
1	ORIGINAL DRAWING	SJ	7.7.10	R.CRIGTON	13.2.14			N/A	
2	FULL PRODUCT REVIEW	RBC	13.2.14						
3									
4									
5									

DUAL CANTILEVER SHELTER 2600mm CENTRES SPEC.

FFSB005006

REV. 2

SHEET 1 OF 3

RevNo	Revision note	Date	Signature	Checked
-------	---------------	------	-----------	---------



A  
B  
C  
D  
E  
F

A  
B  
C  
D  
E  
F

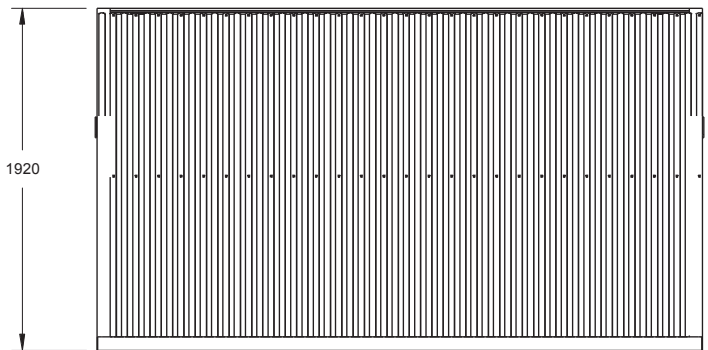
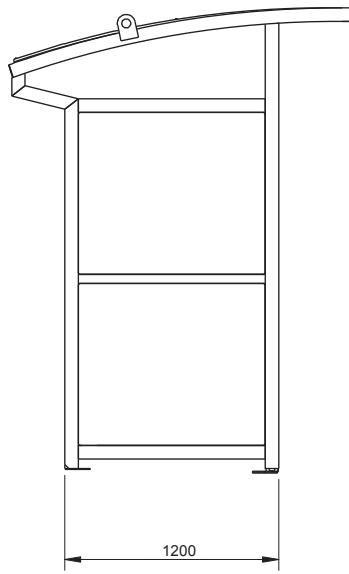
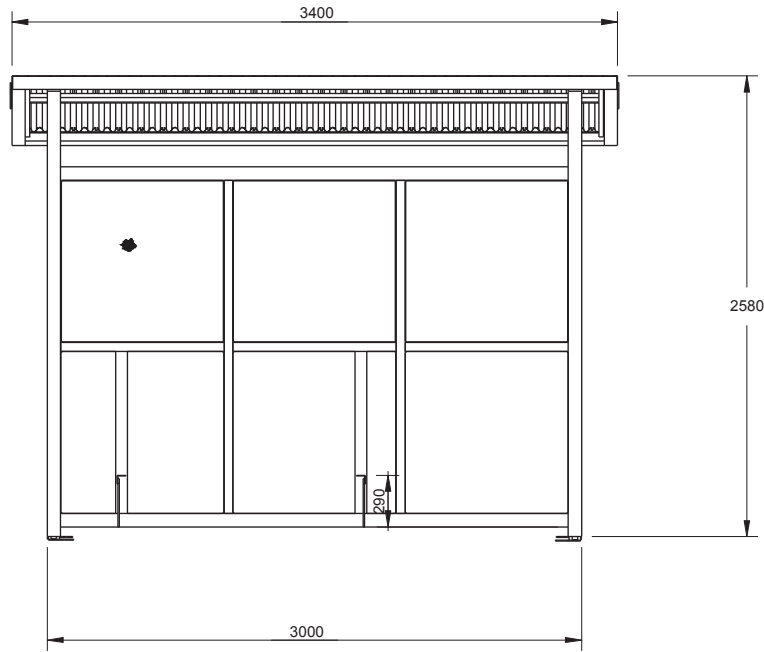

© copyright  
CONFIDENTIAL

Itemref	Quantity	Title/Name, designation, material, dimension etc	Article No./Reference		
Drawn by DAVID NAVIN	Checked by Steve Jones	Approved by - date 30-05-2011	File name FFSB005004	Date 05-05-11	Scale N/A
			PLAYERS/ COACHES SHELTER - SPEC		
			FFSB005004	Edition 001	Sheet 1 Of 8

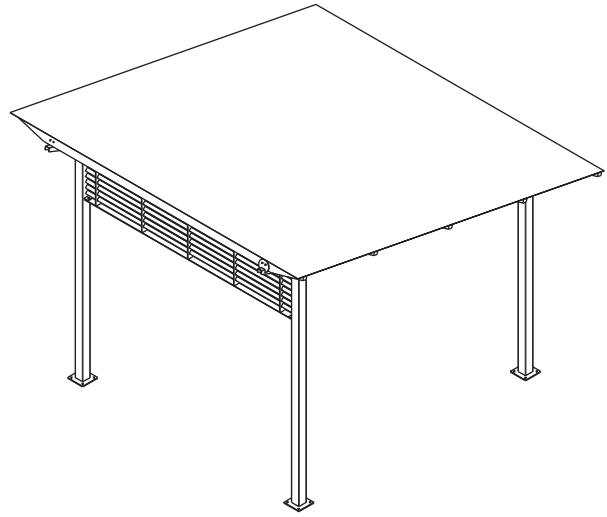
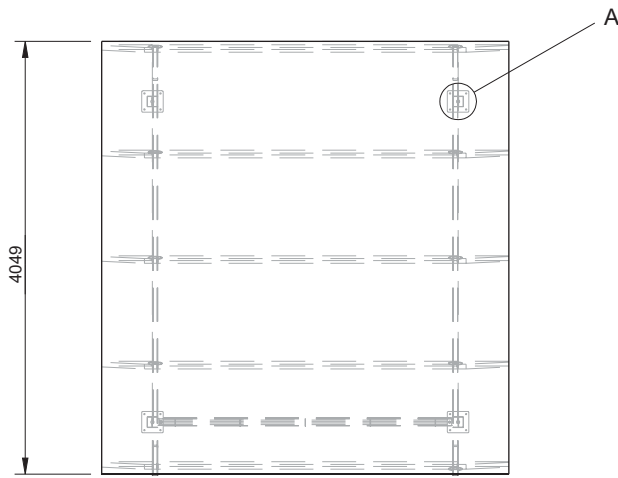

**SPECIFICATION:**

**MATERIAL:**  
Main construction - Mild Steel & Timber  
Sheeting - Colourbond Corrugated BMT 0.42mm 762mm

**DIMENSIONS:**  
mm unless otherwise stated

**FINISH:**  
Steel - Galvanised with optional powdercoat  
Sheeting - Colourbond (optional colours)  
Timber - Treated Pine

**GROUND ATTACHMENT:**  
Bolt down

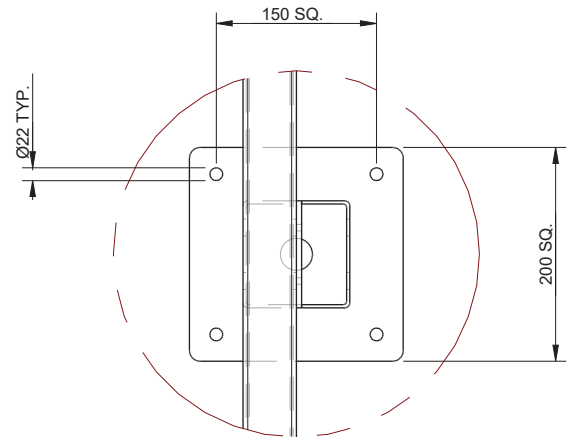
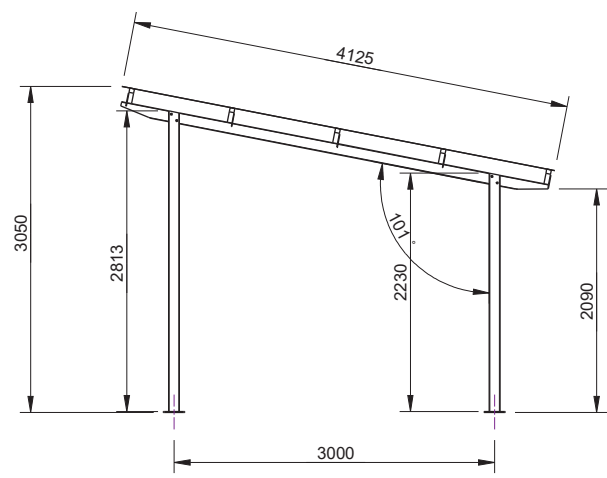
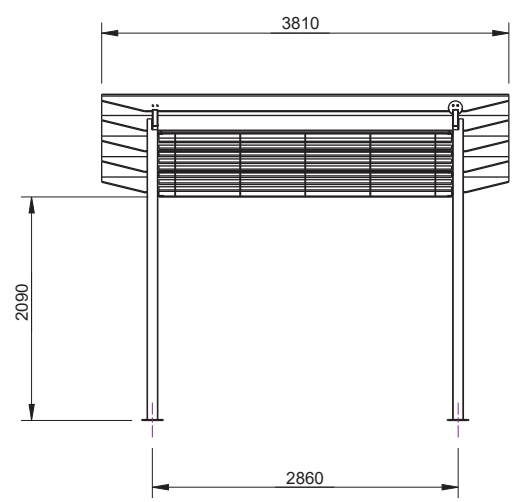

Detail A  
BOLT DOWN DETAIL  
ROOF HIDDEN FOR CLARRITY

REVISION #	DESCRIPTION	BY	DATE	DRAWN	DRAWN DATE	CHECKED	CHECKED DATE	SCALE	A4
1	ORIGINAL DRAWING	SJ	10.4.10	R.CRIGTON	25.2.14			N/A	
2	FULL PRODUCT REVIEW	RBC	25.2.14						
3									
4									
5									

PROVINCIAL SHELTER SPEC.

FFSB005011

REV. 2

SHEET 1 OF 3

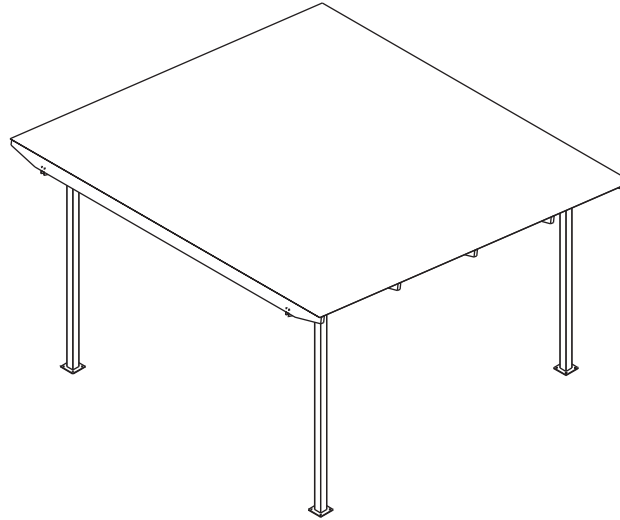
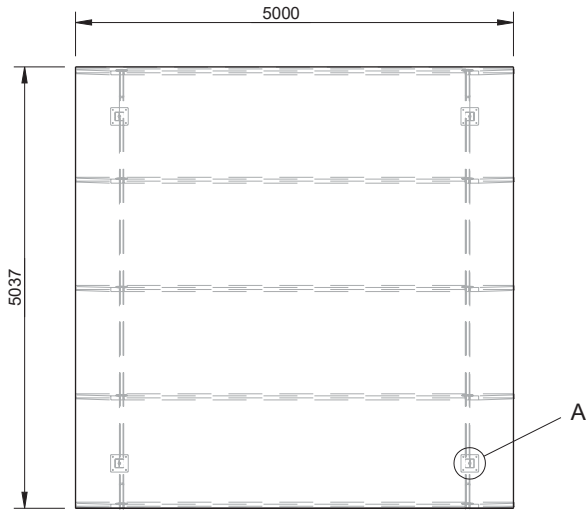

**SPECIFICATION:**

**MATERIAL:**

Main construction - Mild Steel & Timber  
Sheeting - Colourbond Corrugated BMT 0.42mm 762mm

**DIMENSIONS:**

mm unless otherwise stated

**FINISH:**

Steel - Galvanised with optional powdercoat  
Sheeting - Colourbond (optional colours)  
Timber - Treated Pine

**GROUND ATTACHEMENT:**

Bolt down (Sub surface)

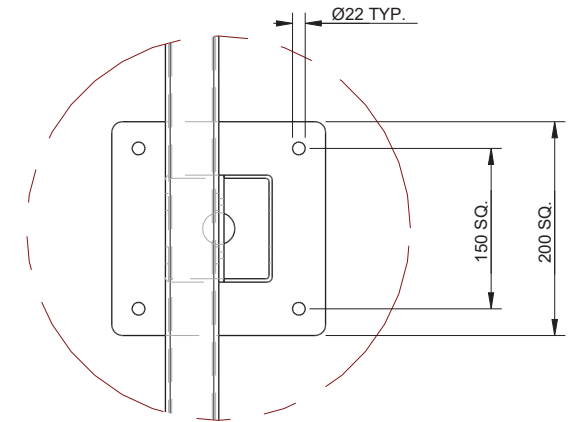
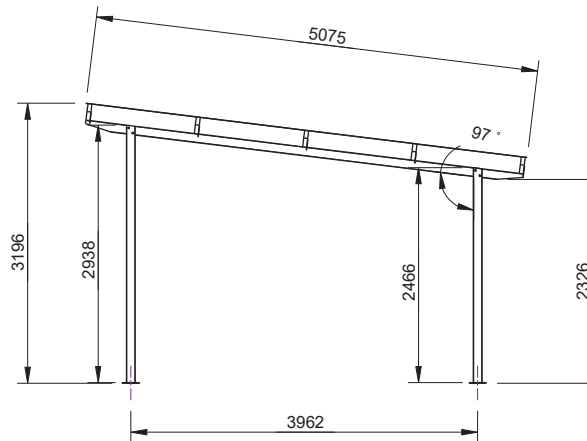
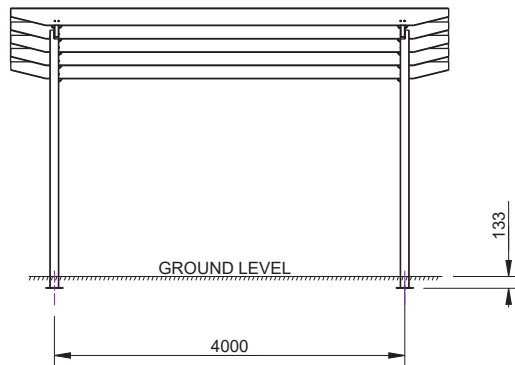

Detail A  
BOLT DOWN DETAIL  
ROOF HIDDEN FOR CLARRITY

REVISION #	DESCRIPTION	BY	DATE	DRAWN	DRAWN DATE	CHECKED	CHECKED DATE	SCALE	A4
1	ORIGINAL DRAWING	SJ	20.10.10	R.CRIGTON	4.3.14			N/A	
2	FULL PRODUCT REVIEW	RBC	3.4.14						
3									
4									
5									

PROVINCIAL SHELTER (5x5)  
SPEC.

FFSB005018

REV. 2

SHEET 1 OF 3

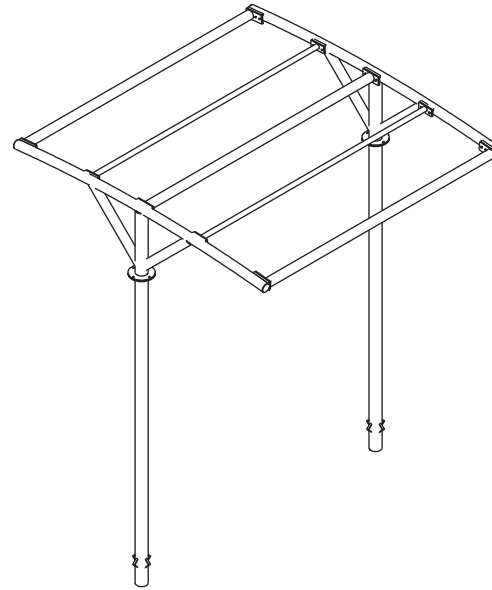
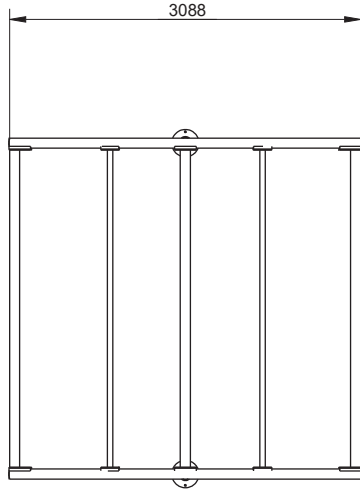

**SPECIFICATION:**

**MATERIAL:**  
 Main construction - Mild Steel

**DIMENSIONS:**  
 mm unless otherwise stated

**FINISH:**  
 Galvanised with optional powdercoat

**GROUND ATTACHEMENT:**  
 In ground

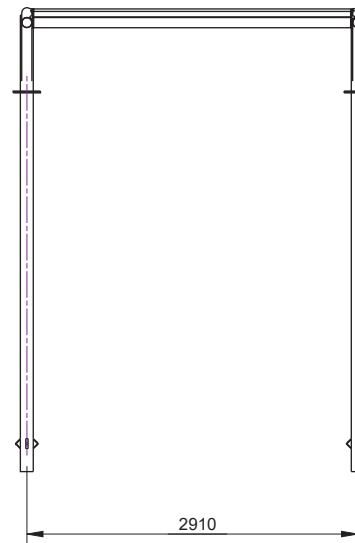
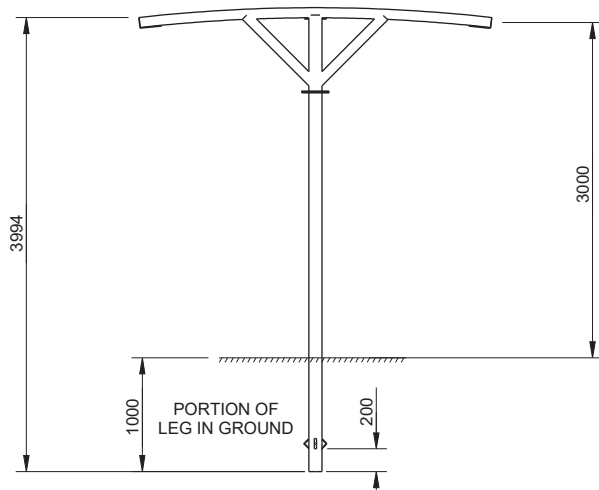

#	DESCRIPTION	BY	DATE	DRAWN	DRAWN DATE	CHECKED	CHECKED DATE	SCALE
1	ORIGINAL DRAWING	RBC	3.5.14	R.CRIGTON	3.5.14			N/A
2								
3								
4								
5								

RAZOR SHELTER SPEC.

FFSB005009

REV.	1	SHEET	1 OF 3
------	---	-------	--------

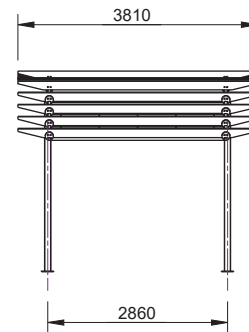
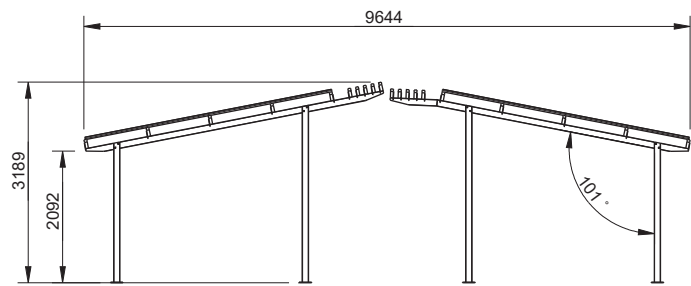
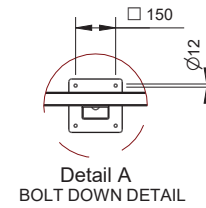
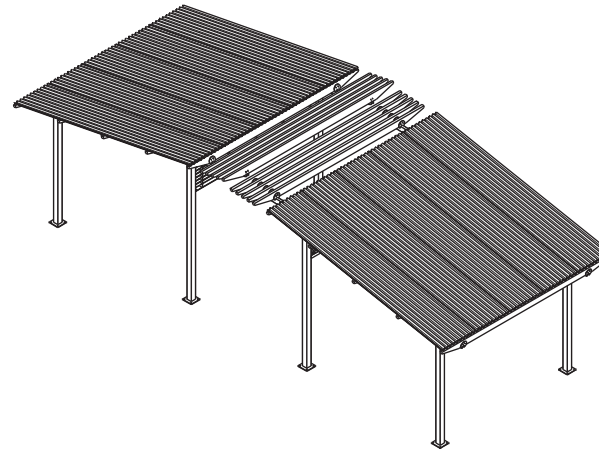
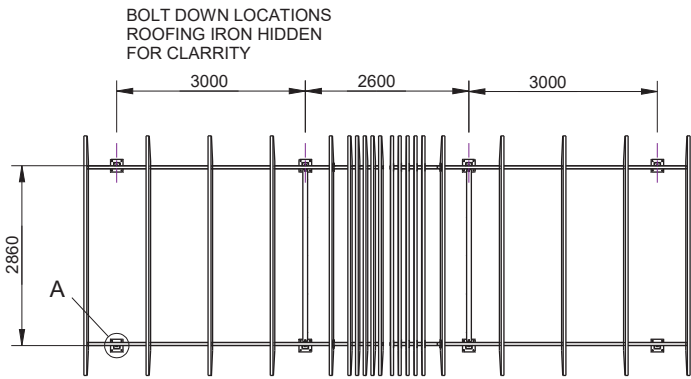

### SPECIFICATION:

**MATERIAL:**

Main construction - Mild Steel & Timber  
Sheeting - Colourbond Corrugated BMT 0.42mm 762mm

**DIMENSIONS:**

mm unless otherwise stated

**FINISH:**

Steel - Galvanised with optional powdercoat  
Sheeting - Colourbond (optional colours)  
Timber - Treated Pine

**GROUND ATTACHMENT:**

Bolt down

#	DESCRIPTION	BY	DATE	DRAWN	DRAWN DATE	CHECKED	CHECKED DATE	SCALE
1	ORIGINAL DRAWING		21.5.14	R.CRIGTON	21.5.14			N/A
2								
3								
4								
5								

REGIONAL SHELTER  
SPEC.

FFSB005012

REV. 1

SHEET 1 OF 3