

A

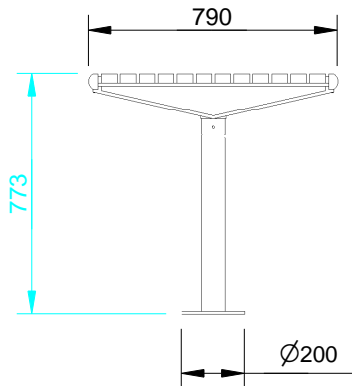

SPECIFICATION:

MATERIAL:

Table Ends & Centre Support - Recycled Cast Aluminium
 Legs - Stainless Steel
 Timber Slats - Hardwood Timber
 Fixings - Stainless Steel

DIMENSIONS:

mm unless otherwise stated

FINISH:

Castings - Mill Finish
 Timber - Oil Based

GROUND FIXING:

Bolt down

WHEELCHAIR ACCESS:

One end

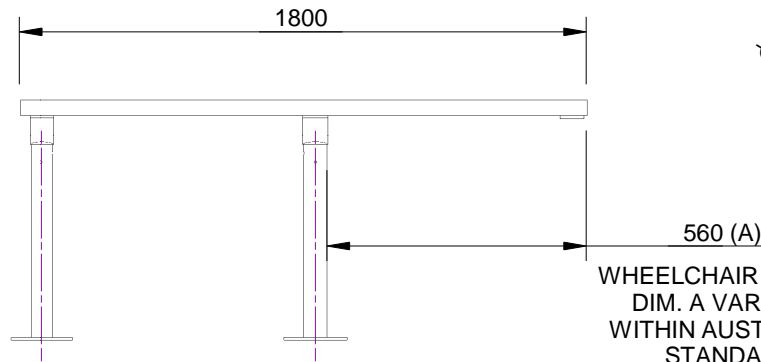

560 (A)
 WHEELCHAIR ACCESS
 DIM. A VARIABLE
 WITHIN AUSTRALIAN
 STANDARD

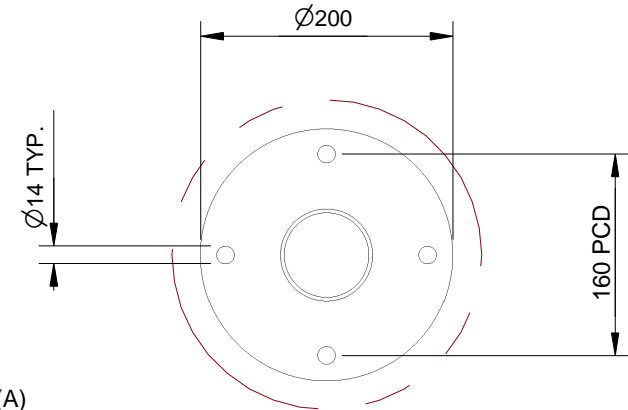
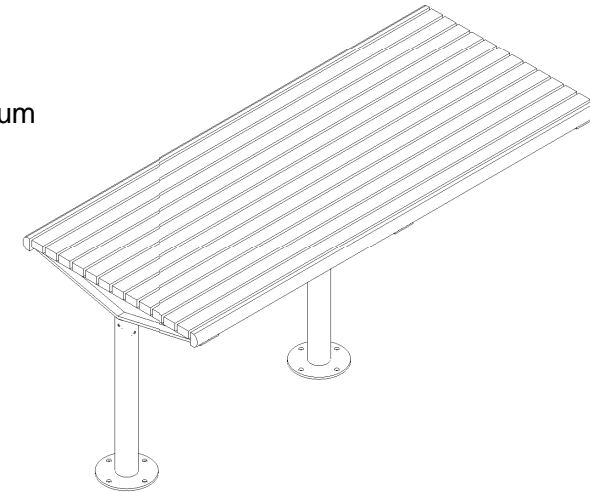

Detail A
 BOLT DOWN DETAIL
 TIMBERS & CASTING
 HIDDEN FOR CLARRITY



copyright

CONFIDENTIAL



Quality
 ISO 9001



REVISION	#	DESCRIPTION	BY	DATE	DRAWN	DRAWN DATE	CHECKED	CHECKED DATE	SCALE	A4
	1	ORIGINAL DRAWING	DN	19.10.10	R.CRIGTON	9.12.13			N/A	
2	FULL PRODUCT REVIEW	RBC	9.12.13							
3										
4										
5										
							PROMENADE TABLE WCA - BOLT DOWN SPEC.			
							FFSA003018	REV. 2	SHEET 1 OF 4	