

SPECIFICATION:

MATERIALS:

Main construction - Cast aluminium
 Slats - Mild Steel
 Support pipes - Mild Steel

DIMENSIONS:

mm unless otherwise stated

FINISH:

Castings - Milled or Powder coat (optional)
 Slats - Galvanised with optional powder coat

GROUND FIXINGS:

Bolt down

WHEEL CHAIR ACCESS:

Both ends



Quality
 ISO 9001

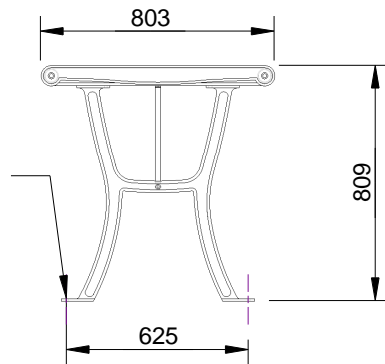

BOLT DOWN DETAIL
 Ø10 THRU
 8 LOCATIONS

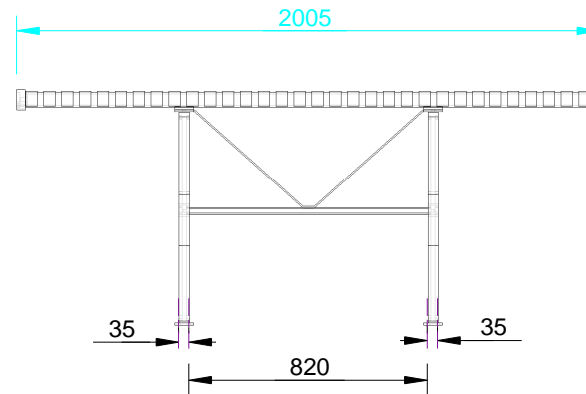

CONFIDENTIAL

REVISION	#	DESCRIPTION	BY	DATE	DRAWN	DRAWN DATE	CHECKED	CHECKED DATE	SCALE	A4
	1	ORIGINAL DRAWING	DN	17.11.10	R.CRIGTON	5.12.13			N/A	
2	FULL PRODUCT REVIEW	RBC	5.12.13							
3										
4										
5										

STEEL SLATTED COUNCIL TABLE SPEC.

FFSA003007

REV. 2

SHEET 1 OF 5