

SPECIFICATION:

MATERIALS:

Main construction - Cast aluminium
 Timbers - Hard wood
 Straps - Stainless steel
 Fixings - Stainless steel



Quality
 ISO 9001
 SAI GLOBAL

DIMENSIONS:

mm unless otherwise stated

FINISH:

Castings - natural
 Timber - Oil based

GROUND FIXINGS:

Bolt down

WHEEL CHAIR ACCESS:

Both ends

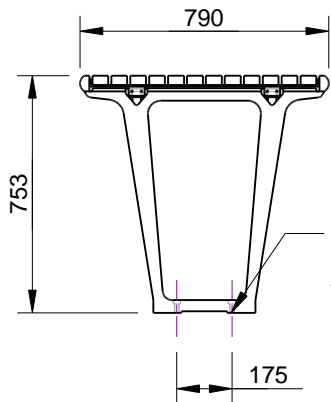

BOLT DOWN DETAIL

Ø14 THRU
 Ø24 C.B.
 4 LOCATIONS

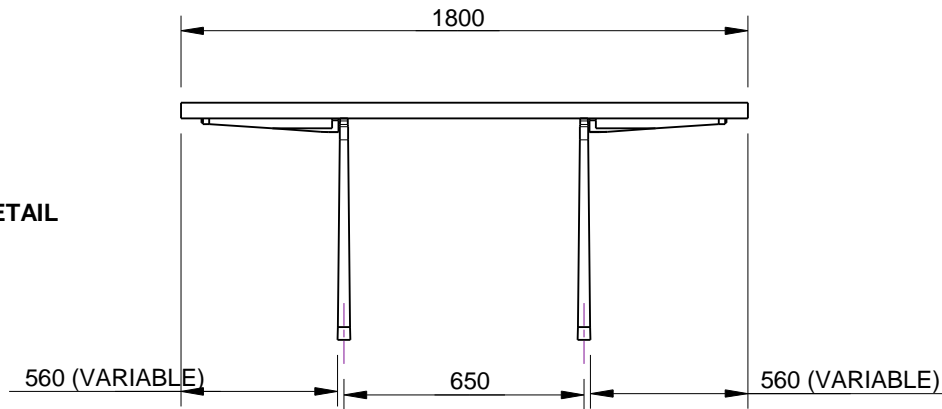

CONFIDENTIAL

REVISION #	DESCRIPTION	BY	DATE	DRAWN	DRAWN DATE	CHECKED	CHECKED DATE	SCALE	A4
								N/A	
1	ORIGINAL DRAWING	DN	22.9.10	R.CRIGTON	4.12.13				
2	FULL PRODUCT REVIEW	RBC	4.12.13						
3									
4									
5									

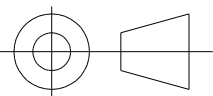

METRO TABLE WCA - BOTH ENDS SPEC.

FFSA003003

REV. 2

SHEET 1 OF 3