

ITEM	PART NUMBER	DESCRIPTION	QTY
1	RSAN30X30X5	EQUAL ANGLE 30x30x5 ROLLED 1219 OD	1
2		1219mm CIRCULAR TREE GRATE CASTING	4
3	RSRB6	ROD 6 DIA 150 LG (BENT 90 DEG)	4

## Procedure

### CASTING

1. Inspect Casting prior to fettling for defects
2. Fettle and repair imperfections
3. Using correct jig mark and drill lug on the underneath of casting to 1/2" (4 holes per section)
4. Using specified indentation in top of casting drill to 17/64" & tap to 5/16"

### ANGLE FRAME

1. Weld rolled angle and dress, ensure 1219 OD
2. Cut 4 off 6mm rod at 150mm and press in center to 90 degrees.
3. Weld 6mm rod to heel of angle frame, horizontal if concrete, vertical if paving.
4. Clean welds and spatter.
5. Inspect final product is dimensional correct Refer opposite.

## Assembly

1. Assembly using 8 off 3/8" x 1 3/4" Hex bolts and nuts and 4 off 5/16" x 1" Hex bolts

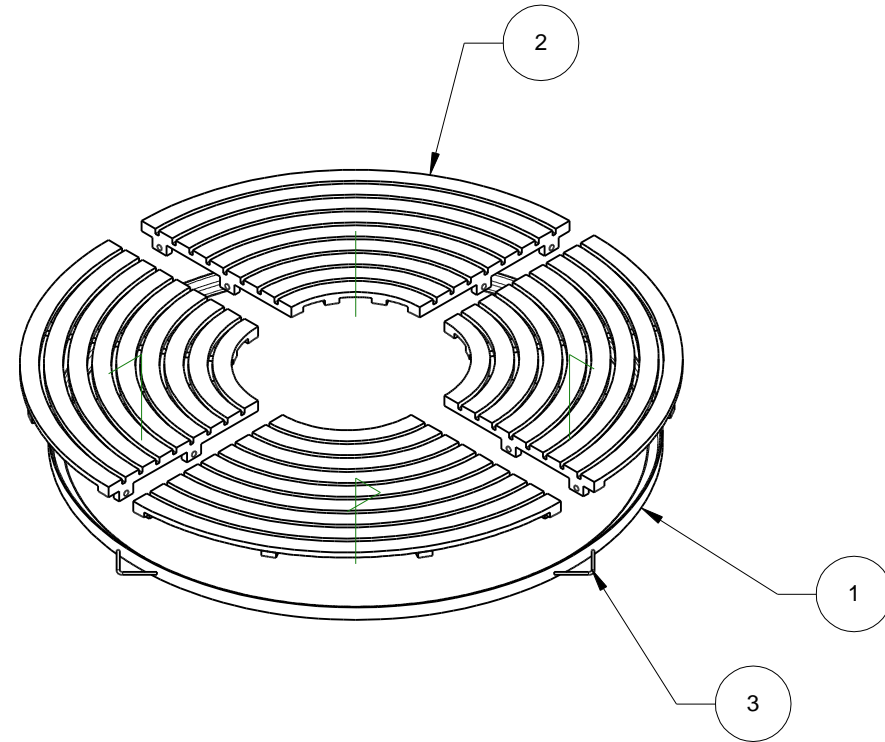

Quality  
ISO 9001  
SAI GLOBAL



CONFIDENTIAL

REVISION	#	DESCRIPTION	BY	DATE	DRAWN	DRAWN DATE	CHECKED	CHECKED DATE	SCALE	A4
	1		ORIGINAL DRAWING			R.CRIGTON	26.3.14			
2										
3										
4										
5										
							1219 CIRCULAR TREE GRATE BOM, PROCEDURE, ASSEMBLY			
							FFSA006007	REV. 1	SHEET 2 OF 2	